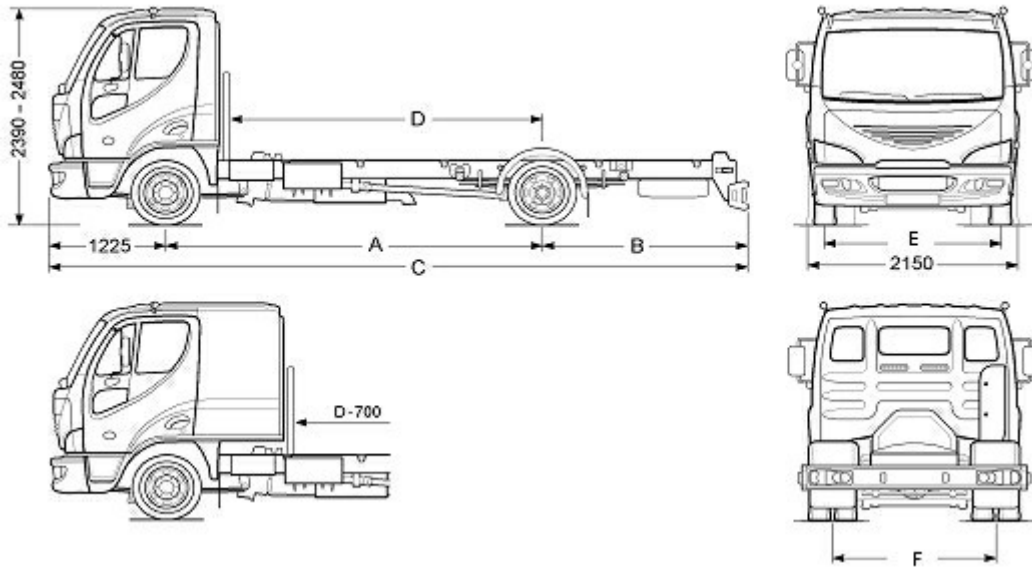

6490 kg GVW
D65-160
D65 -185

AVIA "D" – basic dimensions (mm)							
Wheelbase	A	B	C	D	E	F	D-700
K	2950	1415	5590	2280	1849	1 736	1580
N	3 400	1415	6040	2 730			2030
L	3 900	1 670	6 795	3 230			2530
E	4 500	2 070	7 795	3 830			3130
S	5 100	2 470	8 795	4 430			3730

Heights increase 32mm with 9,5R17,5 tyres
 Maximum body width 2550mm (2600mm fridge)

Weights of chassis (kg)							
Wheelbase	weights			Front axle		Rear axle	
	GVW	chassis	payload	max load	Load from chassis	max load	Load from chassis
K	6490	3325	3165	3400	2168	4450	1157
N		3374	3116		2206		1168
L		3423	3067		2247		1180
E		3472	3018		2287		1185
S		3521	2969		2327		1194

Maximum permissible gross combination weight: 7240 (unbraked) 9990kg (inertia brakes),-11990 kg (service brakes)

Grade ability –(tyres 215/75R17.5)				
	Max theoretic. grade ability %*			
Rear axle ratio	3,73:1	4,10:1	4.56:1	(5.13:1)**
Motor185hp (160 hp)	63	73	87	(110)

real max. grade ability cca 30% depend to adhesion

Speeds –(tyres 215/75R17.5)				
Gearbox ZF 6S850	Rear axle ratio			
Speed km/h at	3.73 :1	4.10 :1	4.56 :1	(5.13 :1)**
1. step at 1000 rpm	5.7	5.2	4,6	4
6.step at 2500 rpm	119	108	97,5	87

** ratio 5,13 :1 only after agreement with producer

Engine rpm at 85 km/h – (tyres 215/75R17.5")				
Rear axle ratio	3,73:1	4,10:1	4.56:1	(5.13.1)**
Engines rpm	1785	1963	2183	(2456)

Engine	
Model	Cummins ISB ^{e4} 160 EURO 4 Cummins ISB ^{e4} 185 EURO 4
Description	High performance direct injection diesel engine. Turbocharged and intercooled. Electronically controlled common rail injection system EURO 4 SCR technology – Ad Blue tank capacity 30 litre
Cylinders	4 in-line
Valves	4 per cylinder
Capacity	4.5 litres
Bore x stroke	107 x 124 mm
Max power	160 hp (117kw) at 2500 rpm 185 hp (136kW) at 2500 rpm
Max torque	602 Nm at 1200 -1700 rpm 700 Nm at 1200-1700 rpm

Clutch	Single dry plate ZF-Sachs. Disc dia. 362 mm, hydraulic operation – air assisted						
Gearbox							
Type	ZF 6S850 6 speed all synchromesh						
Ratios	1°	2°	3°	4°	5°	6°	R
	6.72:1	3.68:1	2.15:1	1.41:1	1.00:1	0.79:1	6.03:1
PTO	With PTO mounting facility ,hand throttle fitted as standard, ratio 1,88 or 1,47						
Rear Axle	Albion 5.14 banjo type axle. Hypoid crown , differential lock, bevel gears differential. 6 studs						
Ratios	3,73:1, 4,10:1, 4.56:1,(5.13:1)**						
Front axle	Albion F36 'I' section, rigid forged beam. 6 studs						
Suspension	Front axle	80mm wide 2 leaf parabolic springs with Ø 32 mm transverse torsion bar stabiliser. Hydraulic double acting shock absorbers					
	Rear axle	80mm wide 3 leaf parabolic springs with Ø 32 mm transverse torsion bar stabiliser. Hydraulic double acting shock absorbers					
Steering	ZF 8090 - Hydraulic, power assisted, monoblock type						
Brakes	Full air system. ABS system. Brake air dryer.						
	Front brakes	Disc brakes (330 mm dia)					
	Rear brakes	Disc brakes (330 mm dia) with load sensing device					
	Parking brakes	Fail safe spring operated park brakes acting on rear axle					
	Exhaust brake	Butterfly valve type, with steering column 4 position electric control					
Frame	Ladder-type, cold riveted and bolted construction with U section side members and open profile cross-members. Side member section 200x60x5 or 203 x 62 x 6.5 mm (S)						
Fuel tank	Steel tank with 120 litre capacity – signalling the minimum reserve of 16 litres. Locking cap.						
Tank for AD-blue	30 l						
Wheel and tyres	215/75R17,5 tyres on 17,5 x 6.00 steel rims. 6 studs. Spare wheel and carrier						
Electrical system	24 volt negative earth system. Batteries 2 x 12v 88Ah capacity. Battery isolation switch Alternator 28V / 80A. Starter 24V / 4Kw.						
Cab	All steel, forward control, two door cab with hydraulic tilt. 2150mm wide across wings. Widespread use of double zinc coated pressed steel panels and wax injected cavities. Plastic cladding panels on front. Noise and thermal isolation, LHS or RHS type						
Cab Suspension	Front mounting points on rubber bushes Two point rear cab suspension system with coil springs and hydraulic shock absorbers and automatic hydraulic lock-down device						
Exterior	Streamlined design with standard front corner spoilers. Front access panel to daily service checks Low level door windows. Tinted cab glass. Heated rear mirrors to suit 2.60m wide body. Electrically operated central door locking. Headlamps adjustable from inside cab. Roof marker lights.						
Interior	Adjustable driver seat, dual passenger seat. Inertia reel seat belts.						SPEC D65 F4

	Storage shelf above windscreen. Storage bin on rear wall. Door pockets. Hinge out document bin Cup holder. Cruise control 24 v socket / cigar lighter. 12v transformer and socket.
Instrumentation	Tachograph, tachometer, fuel, temperature and air gauges, speed control. Full warning light module
Colours	Signal White RAL9003, Traffic Red RAL3020, Red RAL 3005, Gentian Blue RAL5010, , Yellow/Green RAL6018, Green 6016. Full immersion cathoretic water based process
Options	Cab varianty including electrically operated windows S, central locking. Air conditioning and power mirror pack. Isri suspension driver's seat. Front foglamps. Digital clock. Side under- run and rear mudguards. Other RAL colours, metallic silver. 200 litre fuel tank. ASR system. 140 Ah batteries. Drawbar package - rear trailer brake connections and trailer air tank. Differential lock. Adjustable roof spoiler and side fender set Tyres: 225/75R17,5", 9,5R17,5"

Sole Authorised Importer	Avia Ashok Leyland Motors s.r.o. has a policy of continual product improvement. Specifications shown in this data sheet are indicative and not are contractual The manufacturer and importer reserve the right to change specifications at any time without prior notice.
--------------------------	---

,